

Saracco

1906

BIG TIPPER



Big Tipper

This innovative product consist in the manufacture of a mock chassis entirely bolted and galvanized, built with latest generation technologies.



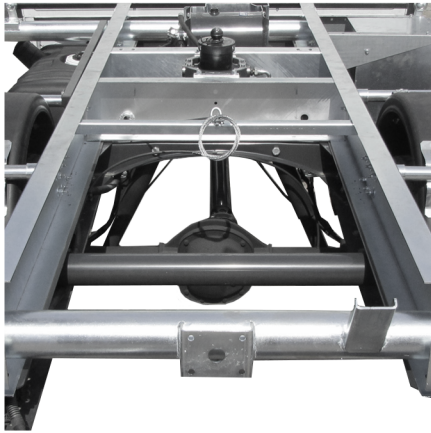

MOCK GALVANIZED CHASSIS

We manufactured a mock chassis entirely **bolted and galvanized**. The **electrolytic galvanizing** process improves durability in time with an excellent anti-corrosion effect.

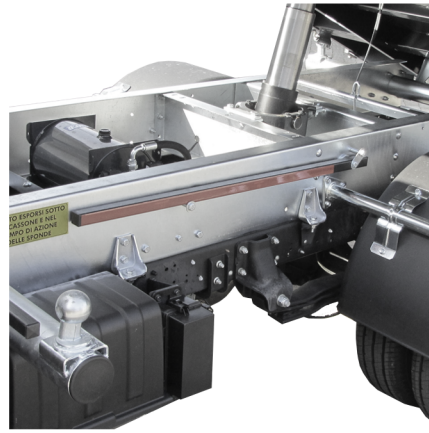

MOCK BOLTED CHASSIS

This new bolted chassis is **removable and interchangeable** so, in the event of an accident, **it is easy to repair separately** and within short times.

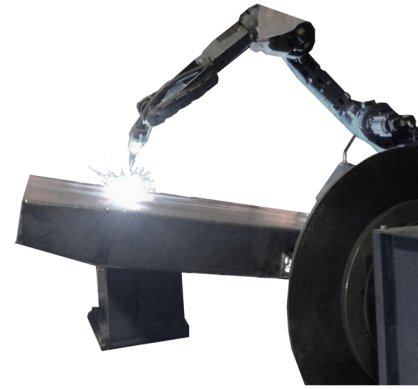

ROBOTIZED TECHNOLOGY

The new tipping body is welded and bent through totally **latest generation technologies**.



PAINTING

The body is painted with sandblasting sa 2.5, water-based epoxy primer (12- 15 micron) and **polyester powder** application (70- 90 micron).



THREE- SIDED TIPPING BODY

New

- **Mock chassis entirely bolted and galvanized**
- Iron bottom 3 mm
- Sides in highly resistant aluminium alloy h 400 mm
- Front side in iron
- Central telescopic piston
- Extractable post holder with perforated sheet
- N° 2 laterally off-set winches
- Forged hooks around the body
- N° 1 galvanized tool box
- Rear mudguards in PVC
- Safety bar for body maintenance
- Buzzer warning that the tipping body is moving
- Safety mesh for taillights

New

- **Painting of the body with dark grey polyester powder ral 7021**
- Labels compliant with safety standards
- EC standards compliant

The logo features the word "Saracco" in a large, elegant, blue cursive script. Below it, the year "1906" is written in a bold, blue, sans-serif font. The entire text is enclosed within a blue, horizontal, oval-shaped swoosh that tapers at both ends. A vertical blue line runs down the right side of the page, starting from the top of the swoosh and extending past the bottom of the page.

Saracco

1906

Saracco Ribaltabili SRL

Strada cullà 6
Moncalieri (TO), 10024
P.IVA: 02759060011

Tel: 011 642458

Tel: 011 6407209

Fax: 011 6408316

www.saraccoribaltabili.com

email: saraccoribaltabili@saraccoribaltabili.com

SALES MANAGER

Lorenzo Saracco

Tel: 335 6031955